

HURST

HURST PERFORMANCE SERIES BOILERS

STANDARD FEATURES

- Boiler is of the three-pass, scotch type, built and stamped in accordance with the requirements of the ASME Code, and listed by the National Board of Boilers and Pressure Vessel Inspectors.
- Large combustion chamber with low heat release for complete combustion.
- Smoke box is rear-mounted with slip-on stack connector.
- Access to fireside is accomplished with hinged and davited front and rear doors. Flame observation ports are located on front and rear.
- Openings for vessel cleanout and inspection of waterside are provided with 3" x 4" hand holes, and 12" x 16" manway access.
- Insulated with 2" high density mineral wool, lagged with 22 gage grip jacketing, baked on finish to resist chipping and fading.
- Firetubes are rolled and beaded on power boilers, expanded and flared on low pressure boilers
- Supports include lifting lugs securely welded to the top of shell; structural steel support legs on skids support the boiler so that special foundations are not required.

Stress Relieving "Wetback" Construction for Extra-Long Life

Standard Steam Trim

- Operating & high limit pressure control
- Modulating pressure control (when appl.)
- Water column with gauge glass, combination low water cut-off & pump control
- Probe Aux, L.W.C.O.
Steam pressure gauge, syphon & test cock
- Water column drain valve
- Safety relief valve(s) per ASME Code

Standard Water Trim

- Operating & high limit temperature control
- Modulating temperature control (when appl.)
- Probe type low water cut-off control
- Combination pressure & temperature gauge
- Hot water return baffle for shock resistance
- Safety relief valve(s) per ASME Code

HBC-09503
01/2011



 **hurstboiler.com**
HURST BOILER & WELDING CO., INC.

100 Boilermaker Lane • Coolidge, GA 31738-0530
Tel: (229) 346-3545 • Fax: (229) 346-3874
email: info@hurstboiler.com



HURST

BOILER & WELDING CO., INC

AVAILABLE WITH LOW NOX

SERIES EURO

3-PASS FIRETUBE DESIGN
Wetback Construction
100 - 2000 BHP

STEAM
Pressures to 15-300 PSI.

HOT WATER
Section I and Section IV



Low Profile
Compact Design

Wet Back Design Eliminates Refractory
Rear Door & Baffles Between
Flue Gas Passes



SHIPS IN
FREIGHT CONTAINER

HURST PERFORMANCE SERIES BOILERS



NOTE: THE 400 HP SIZE HAS A REMOVABLE STACK SECT'N. FOR SHIPPING CONSULT FACTORY

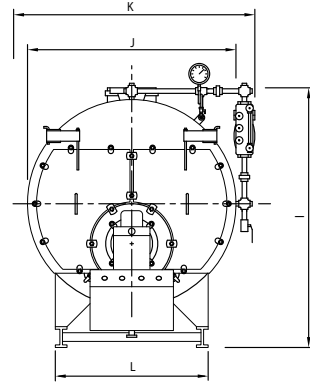

FRONT VIEW

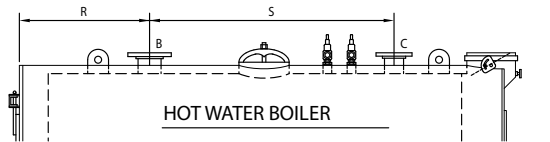

HOT WATER BOILER

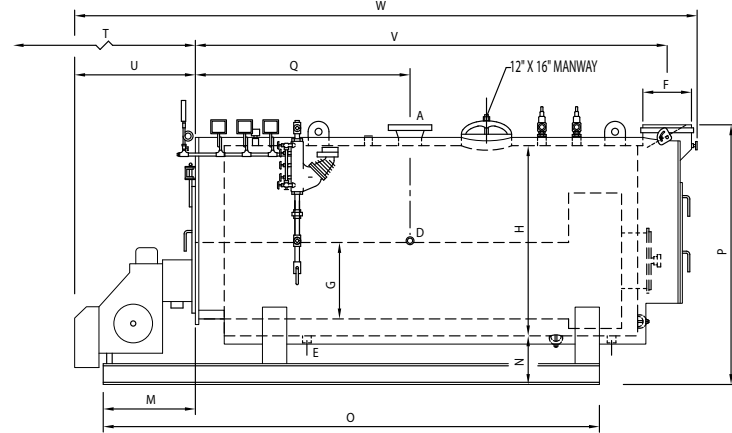

SIDE VIEW

CUT AWAY VIEW

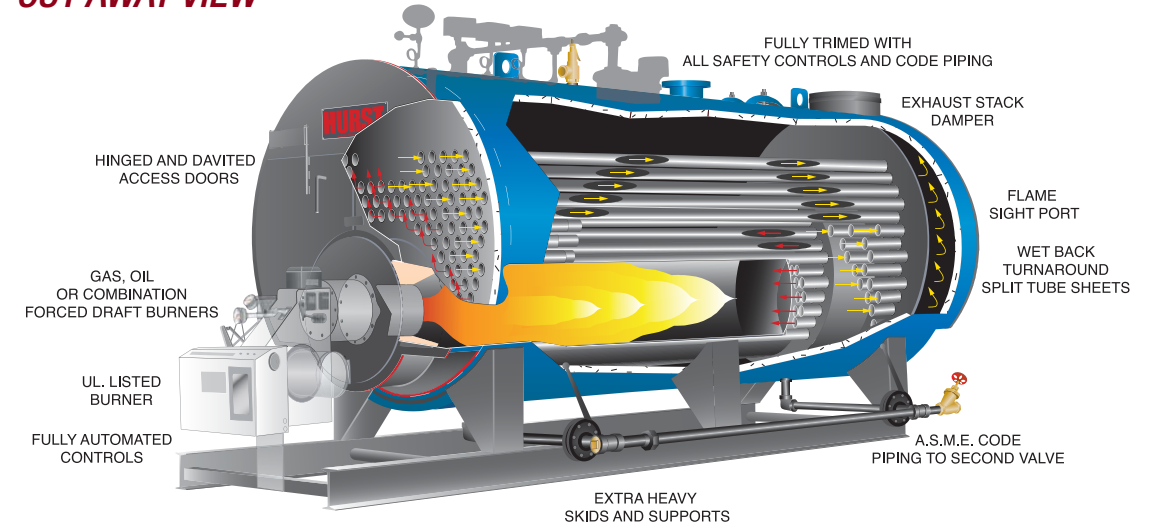

BOILER SPECIFICATIONS

BOILER HORSEPOWER			100	125	150	200	250	300	350	400	
STEAM OUTPUT	FROM & @ 212"	LBS/HR	3450	4313	5175	6900	8625	10350	12075	13800	
GROSS OUTPUT	@33,475 BTU/BHP	MBH	3348	4184	5021	6695	8369	10043	11716	13390	
FIRING RATE GAS	1,000 BTU	CFH	4200	5250	6300	8400	10500	12600	14700	16800	
FIRING RATE LP GAS	91,500 BTU	GPH	46	57	69	92	115	138	160	184	
FIRING RATE OIL #2	140,000 BTU	GPH	29.9	37.4	45	60	75	90	105	120	
FIRING RATE OIL #5 & #6	150,000 BTU	GPH	28	35	42	56	70	84	98	112	
A	*NOTE: 1 STEAM OUTLET SIZE	150 PSI	IN	4	4	4	4	6	6	6	
A	*NOTE: 2 STEAM OUTLET SIZE	15 PSI	IN	8	8	8	8	10	10	10	
B	*NOTE: 2 WATER SUPPLY SIZE	30 PSI	IN	8	8	8	8	10	10	10	
C	*NOTE: 2 WATER RETURN SIZE	30 PSI	IN	6	6	6	6	8	8	8	
D	FEEDWATER CONNECTION		IN	1 1/4	1 1/4	1 1/4	1 1/2	1 1/2	2	2	
E	BLOWDOWN CONNECTION (BTM)	HIGH PRESS.	IN	1 1/4	1 1/4	1 1/4	1 1/4	1 1/2	1 1/2	1 1/2	
E	BLOWDOWN CONNECTION (BTM)	LOW PRESS. & HW	IN	1 1/2	1 1/2	2	2	2	2	2	
F	STACK OUTLET SIZE O.D.		IN	14	14	16	16	18	20	24	
G	FURNACE O.D.		IN	30	30	35 1/4	35 1/4	38	38	44	
H	SHELL I.D.		IN	54	54	66	66	72	75 1/2	78	
I	NOTE: 3 SUPPLY HEIGHT	150 PSI	IN	74 5/8	74 5/8	87 3/4	87 3/4	93 3/4	97 1/2	93 5/8	
J	WIDTH WITHOUT TRIM		IN	60	60	73	73	78	83	85	
K	WIDTH WITH TRIM		IN	67	67	80	80	87	89	91	
L	SKID WIDTH		IN	44	44	51	51	57	60	62	
M	END OF SKID FROM FRT. PLATE		IN	19 11/16	21 11/16	22 11/16	22 11/16	28 5/8	31 5/8	36	
N	SHELL TO FLOOR		IN	14	14	15	15	15	15	14	
O	SKID LENGTH		IN	120	134	159	165	180	206	236	
P	STACK HEIGHT		IN	74 5/8	74 5/8	87 3/4	87 3/4	93 3/4	97 1/2	104	
Q	STEAM OUTLET LOCATION	15 & 150 PSI	IN	55 13/16	55 13/16	63 13/16	63 13/16	67 7/8	82 7/8	103 7/8	
R	SUPPLY LOCATION		IN	35 13/16	35 13/16	39 13/16	39 13/16	45 7/8	50 7/8	55 7/8	
S	RETURN LOCATION		IN	56	68	80	84	86	96	114	
T	TUBE REMOVAL	FRONT	IN	111	123	144	150	161	176	209	
U	BURNER PROJECTION	STANDARD BURNER	IN	32	35	35	35	48	52	52	
V	STACK OUTLET		IN	119 13/16	131 13/16	153 13/16	159 13/16	171 7/8	187 7/8	221 7/8	
W	APPROX. OVERALL LENGTH		IN	162	177	200	206	232	253	263	
	OVERALL SHIPPING HEIGHT	30 & 150 PSI	IN	76	76	89	89	95	99	96	
	SHIPPING WEIGHT - HIGH PRESS.	150 PSI	LBS	8,300	9,000	13,500	14,650	17,250	20,500	26,000	
	WATER CAPACITY - STEAM	NWL	GALS	516	579	1025	967	1406	1538	1748	
	WATER CAPACITY - WATER	FLOODED	GALS	573	643	1222	1218	1648	1949	2166	
	BOILER HORSEPOWER			100	125	150	200	250	300	350	400

Inspected and registered with the National Board of Boiler & Pressure Vessel Inspectors.



Designed, constructed and stamped in accordance with the requirements of the ASME Boiler Codes.

	500	600	700	750	800	900	1000	1200	1500	1800	2000
A	6	8	8	8	8	8	8	10	10	*12	*12
A	10	12	12	12	12	14	14	14	14	*16	*16
B	10	12	12	12	12	12	12	14	14	*16	*16
C	8	8	10	10	10	12	12	14	14	*16	*16
D	2	2 1/2	2 1/2	2 1/2	2 1/2	2 1/2	2 1/2	2 1/2	2 1/2	2 1/2	2 1/2
E	1 1/2	1 1/2	2	2	2	2	2	2	2	2	2
E	2	2	2	2	2	2	2	2	2 1/2	2 1/2	2 1/2
F	24	28	34	34	34	34	34	38	42	*48	*48
G	50	54	56	56	60	60	60	60	62	66	66
H	96	102	108	108	112	112	112	126	136	142	142
I	121	127	133	133	137 1/4	137 1/4	137 1/4	152 1/4	162 1/2	162	162
J	102 3/4	108	115	115	119	119	119	133 1/2	144 1/2	149	149
K	108 1/4	113 1/4	124	124	136	136	136	139 1/2	150 3/4	161	161
L	76	78	86	86	92	92	92	108	114	124	124
M	31 5/8	52 5/8	46 5/8	46 5/8	36 5/8	52 1/2	51 1/2	55 5/8	59 5/8	70	76
N	18	18	18	18	18	18	18	18	18	16	16
O	212	240	228	228	228	264	288	294	320	336	354
P	122	128	134	134	138 1/4	138 1/4	138 1/4	152 1/4	162 1/2	162	162
Q	96 7/8	96 3/8	89 7/8	90 1/2	101 3/8	122	116	122 3/8	135 7/8	134	140
R	60 3/8	66 3/8	60 7/8	60 7/8	63	68	75	75	74	74	74
S	162 3/8	168 3/8	162 7/8	162 7/8	165	188	206	206	218	218	230
T	195	202	196	196	209	231	253	281	281	281	293
U	65	66	66	70	70	75	75	84	84	96	96
V	208 7/8	217 7/8	214 3/8	214 3/8	225 7/8	249 1/2	271 1/2	273 1/2	302 7/8	307	319
W	279	290	299 3/8	303 3/8	312	343 1/2	365 1/2	379	405	429	441
	122	128	134	138 1/4	138 1/4	138 1/4	138 1/4	152 1/4	162 1/2	164	164
	35,000	38,000	43,000	44,200	49,500	53,750	57,500	72,000	89,000	*89,000	*92,000
	2390	2688	3405	3348	3590	4015	4443	5855	7176	5855	7165
	3453	3983	4290	4233	4823	5152	5697	7980	10,386	7980	10,532
	500	600	700	750	800	900	1000	1200	1500	1800	2000

BOILER DESIGN: Three-Pass "Scotch Marine" Firetube design with stress relieving "Wetback" construction. Pressure designs for steam are 15-300 psi. 100-600 hp. 250 psi. max. for 700-1500 hp. and 200 psi. max. for 1800-2000 hp. Hot Water pressures models are from 30-160 psi. High pressure, high temperature Section I hot water boilers available. Factory assembled with trim, tested, ASME code, UL, and CSD-1 standards.

STEAM MODEL TRIM: Safety relief valve, operating pressure control, high limit pressure control with manual reset, steam pressure gauge with syphon, combination pump control and low water cut-off with gauge glass assembly and drain valve, auxiliary low water cut-off with manual reset.

HOT WATER MODEL TRIM: Safety relief valve, operating temperature control, high limit temperature control with manual reset, combination pressure & temperature gauge, low water cut-off control with manual reset.

BURNER: Matched UL listed "forced draft" power burners with factory pre-piped, wired and tested fuel configurations for natural gas, propane (LP) gas, No. 2 (diesel) oil, or combination of both gas/oil.

DIMENSIONS SUBJECT TO CHANGE WITHOUT NOTICE. (NOTE:1) 3" & ABOVE ARE 300# ANSI FLANGE. (NOTE:2) 4" & ABOVE ARE 150# ANSI FLANGE.

FOR SECT.-I HIGH-PRESS. STEAM THIS CHART APPLICABLE FOR 50 PSI UP TO 300 PSI. STEAM AND LOW AND HIGH PRESS. HOT WATER ONLY. FOR STEAM PRESSURES BELOW 50 PSI. AND FOR SECTION-IV LOW PRESS. STEAM BELOW 150 PSI. CONSULT FACTORY FOR BOILER DIMENSIONS AND OR CERTIFIED DWGS.

* NOTE: 1800 & 2000 HP WEIGHTS DO NOT INCLUDE BURNER OR REFRACTORY HEAD RING. * NOTE: STUDDER OUTLET FLG'S ON 400 HP, 1800-2000 HP.

MORE CHOICES SOLUTIONS